

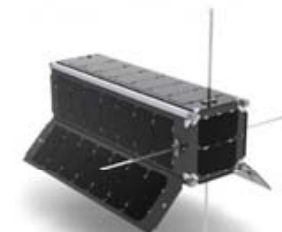

MYPOCKETQUB IQEA 442

an open source spacecraft payload



Anum Ali
Alex Allan
Radim Badsı
Jordi Barrera
Merlin Barschke
Adam Brookes
James Cooper
Roger Duthie
Jihan Farzana
Nadeem Gabbani
Abhinav Garg
Toivo Hartikainen
Matt Hearn
Andrew Henry
Nancy Hine
Alex Hocking
Muthu Krishna

Johan Marx
Rob Morse
Adam Moore
Alex Narduzzo
Senol Ozkan
Dale Potts
Jinesh Ramachandran
Paul Rernaud
Trevor Seabrook
Rupert Taylor
Johannes van der Horst
Alonzo Vera
Antoine Verhaeghe
Camilla Weiss
and others

Cranfield University
Exmouth Community College
Lancaster University
Open University
UCL / MSSL
University of Bath
University of Bristol
University of Huddersfield
University of Southampton
University of Surrey
and others

Michael Johnson
spaceprojects@ukseds.org

UKSEDS Annual
Conference, February 2011

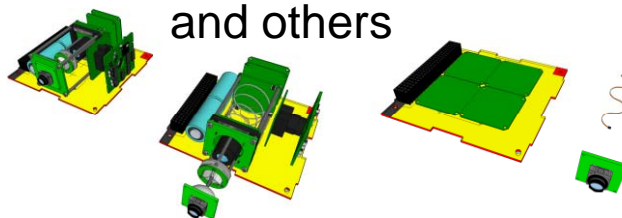



The story so far...

Michael Johnson, Project lead

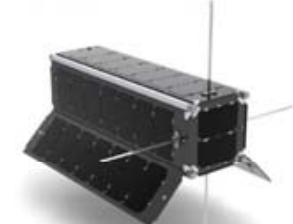

- November 2010
 - UKube Announcement of Opportunity
 - UKSEDS Satellite Workshop at NLO recruits team
 - >35 people join us: spaceprojects@ukseds.org
- December 2010 Proposal submitted
- January 2011 Selected for shortlist of seven
- February 2011 Part sourcing, UKSA questions
- **March 2011** **Down selection**
- If we survive down selection:
 - March 2011 Assembly
 - April - June 2011 Testing / rework
 - July 2011 Integration
 - December 2011 Liftoff!
 - 2011-201? Operations

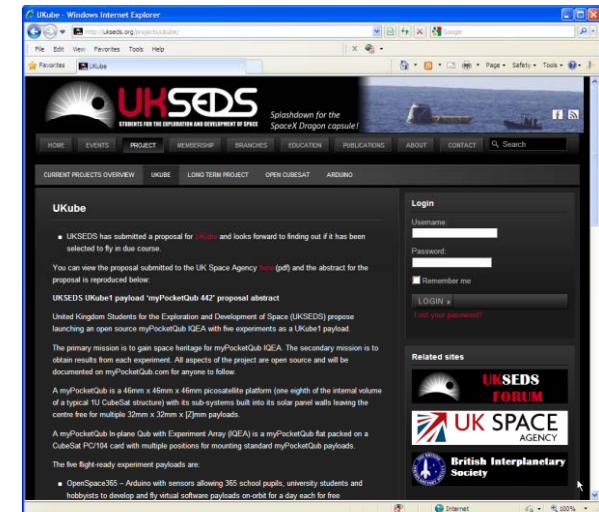
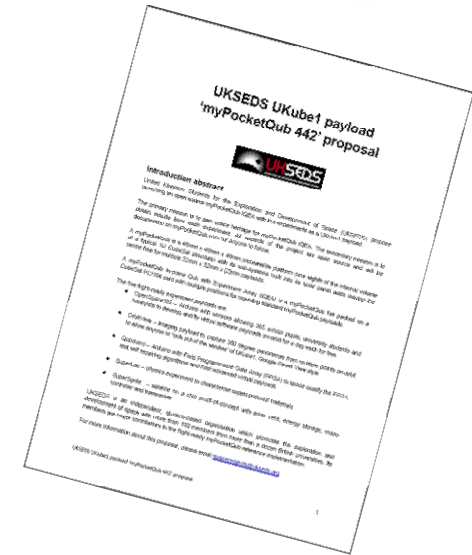

ukseds.org/projects/ukube



Brief overview

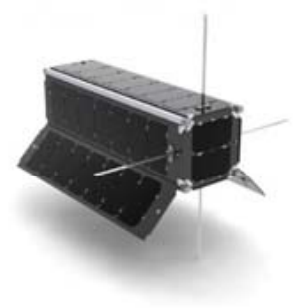

myPocketQub IQEA + vRadio + PocketPayloads:

- **OpenSpace365**
 - Arduino with sensors allowing 365 school pupils, university students or hobbyists to develop and fly virtual software payloads on-orbit for a day each for free
- **OrbitView**
 - imaging payload to capture 360 degree panoramas from multiple points on-orbit to allow anyone to 'look out of the window' of UKube1, Google Street View style
- **Qubduino+**
 - Arduino with Field Programmable Gate Array (FPGA) to space qualify the FPGA, test self repairing algorithms and host advanced virtual payloads
- **SuperLab**
 - physics experiment to characterise superconductor materials
- **SuperSprite**
 - satellite on a chip proof-of-concept with solar cells, energy storage, micro-controller and transceiver

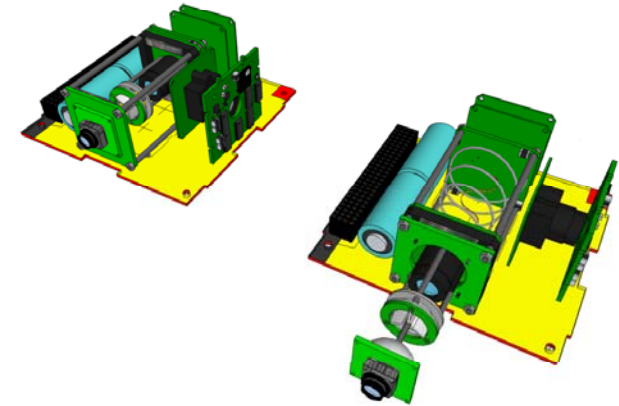

Full height configuration

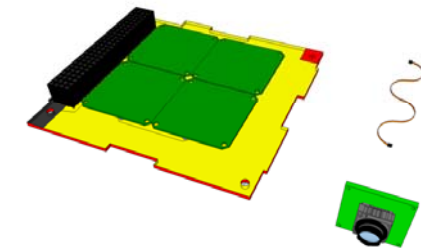

Low profile configuration



System overview

(Johannes van der Horst, Engineering Lead)

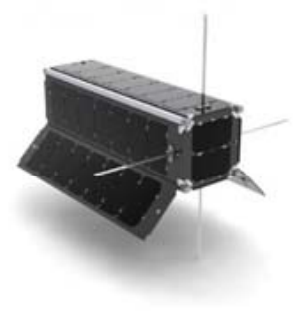

- Payload controller bridges two worlds
 - UKube on one side ($I2C_U$ / SPI)
 - myPocketQub IQEA + payloads on other ($I2C_{MPQ}$)
- Infrastructure
 - Interface
 - Control payloads
 - Retrieve data
 - Manage sensors
- Many AVR microcontrollers (Arduinos)



Functional architecture

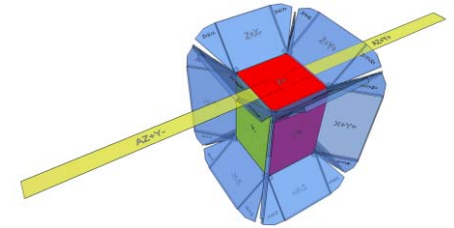
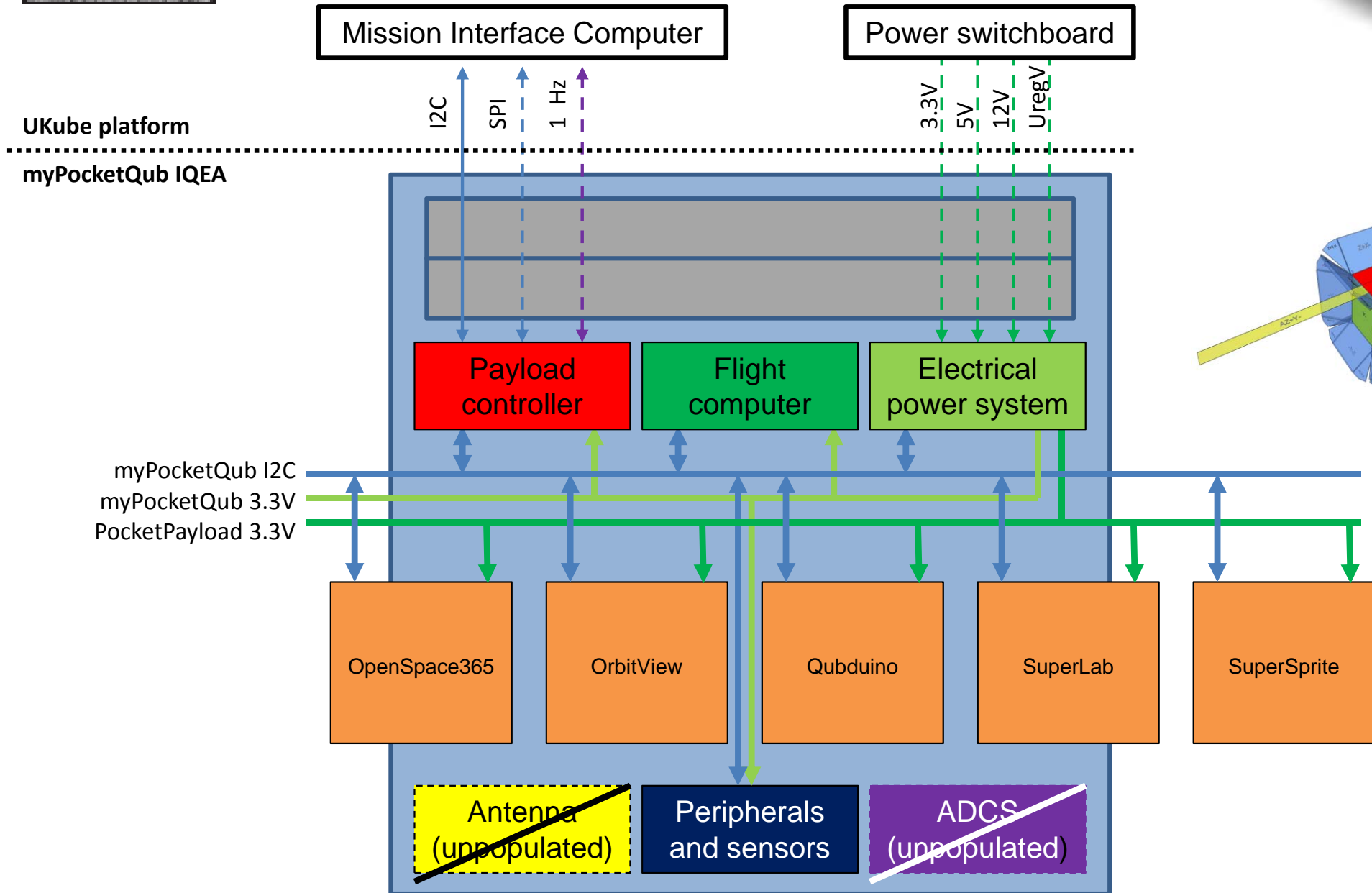
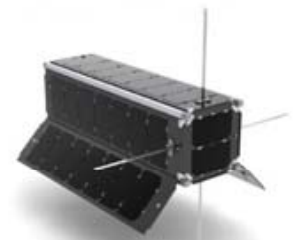



Payload: OrbitView

Dale Potts, OrbitView lead

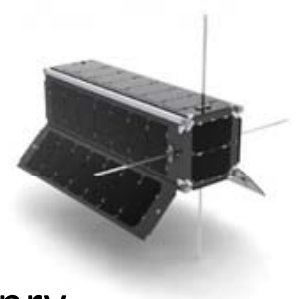

Adam Brookes, Roger Duthie, Nadeem Gabbani, Abhinav Garg, Andrew Henry, Toivo Hartikainen, Johan Marx, Rupert Taylor and others

- Two camera payload

- ‘Universe camera’ serendipitously images Earth and space as satellite rotates
- ‘Satellite camera’ uses catadioptric (mirror and lens) to image satellite with hemispherical mirror

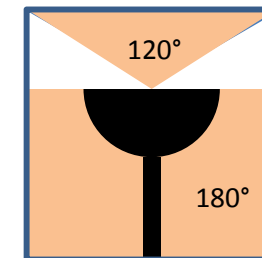
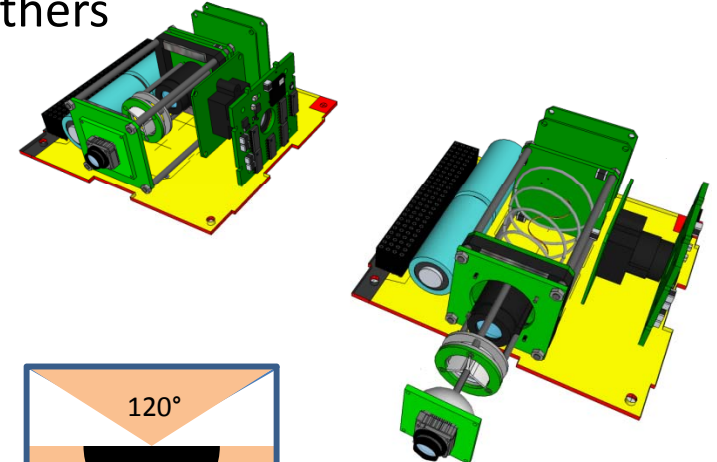

- Cameras

- 4D Systems uCam
 - Well understood (used by standalone myPocketQub)
 - Serial TTL camera module
 - 1/4" CMOS
- Micron/Aptina 1/2.5" CMOS Sensor MT9P011
 - 10mm (W) x 10mm(D) x 8.7mm (H)
 - 5 megapixels (2582 x 1944 pixels)

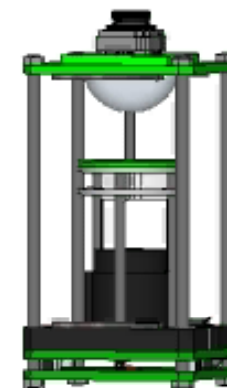

Views from UKube1 on:

Date: 31st December 2011 00:00Z

Altitude: 700km

Longitude: 0.0.0

Latitude: 0.0.0

Satellite panorama – drag image:



Universe panorama – drag image:



NASA/courtesy of nasaimages.org

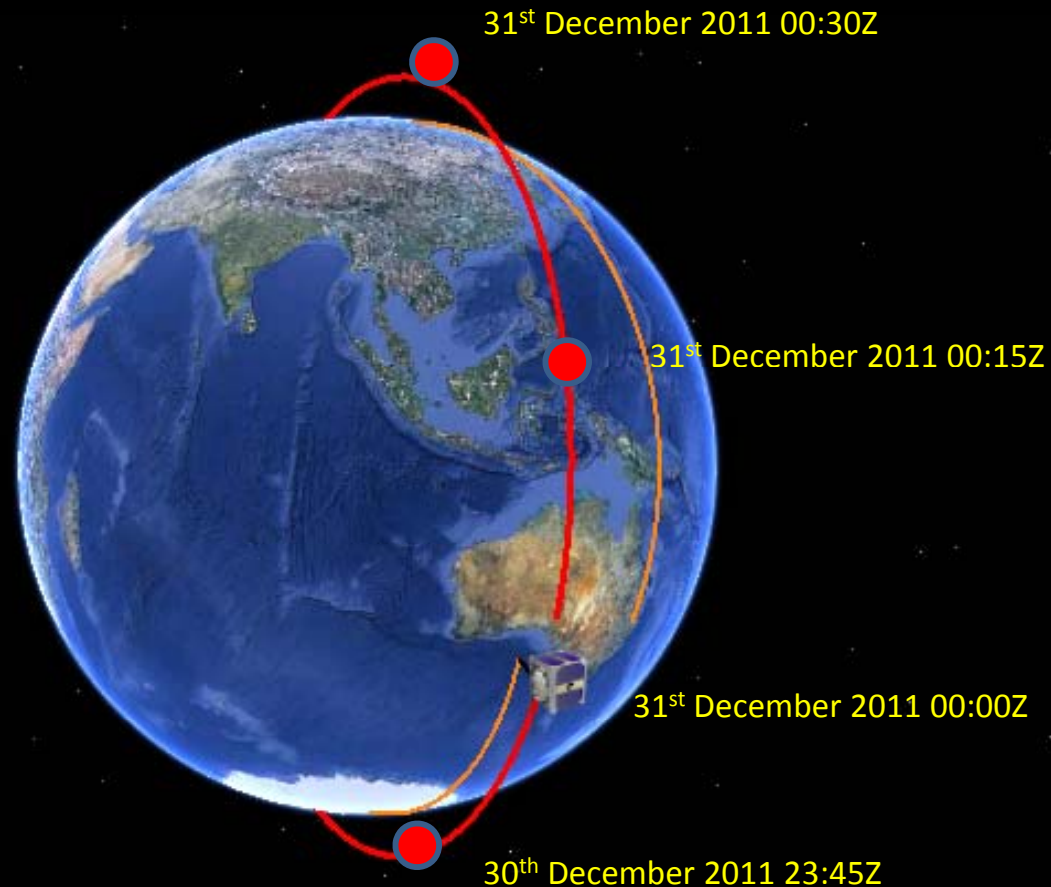

Data SIO, NOAA, U.S. Navy, NGA, GEBCO
Image IBCAO



Click on the red dots to view space from a specific point on orbit on the date and time specified!

Mockup images: AeroSpace Corp, Google, NASA, Solenix



SuperSprite

Adam Brookes, SuperSprite lead
Michael Johnson and others

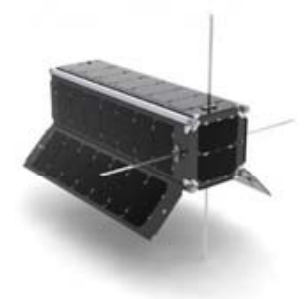

- Collaboration with SSDS at Cornell University
- Sprite – ‘satellite-on-a-chip’ proof of concept with solar cells, energy storage, micro-controller, and transceiver
 - Sprite (transmit only) to be launched on STS-134 in April as part of MISSE-8
 - SuperSprite (transceiver) fits around OrbitView universe camera
- Operates in 70cm amateur radio band Direct-Sequence Spread Spectrum (DSSS) 437.425-437.525MHz (IARU coordinated)
- UKube / myPocketQUB IQEA are able to deactivate SuperSprite to comply with IARU / UKSA guidelines

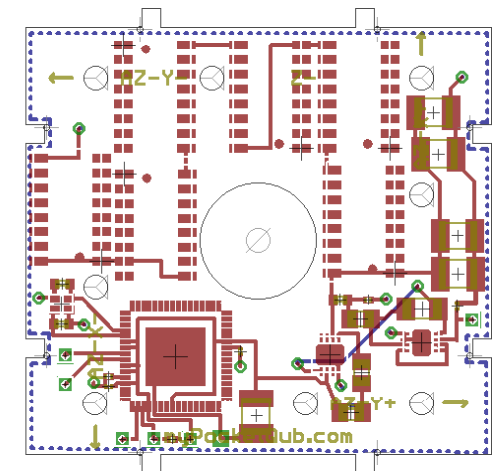
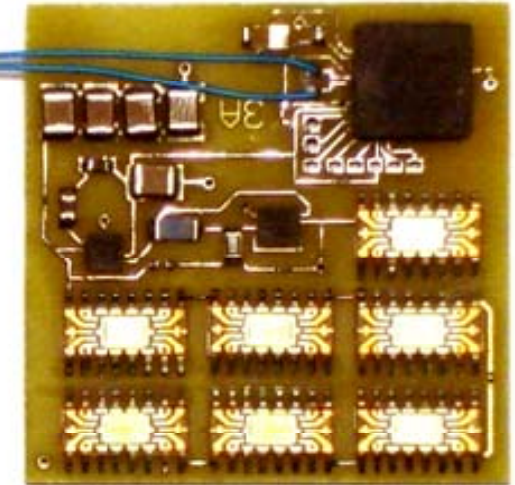



SuperLab

(Rupert Taylor, SuperLab lead)

Adam Brookes, Alex Narduzzo and others

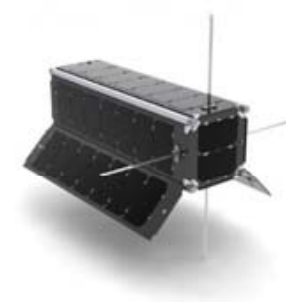

- Thin film superconductor material experiments
- Test feasibility of temperature dependent conductivity measurements in space
- Test methods of mounting thin film superconductors for novel applications
- Temperature cycle of sample material will depend on orbit
- Circuit measures resistivity
- Up to four samples to including yttrium barium copper oxide (YBCO)

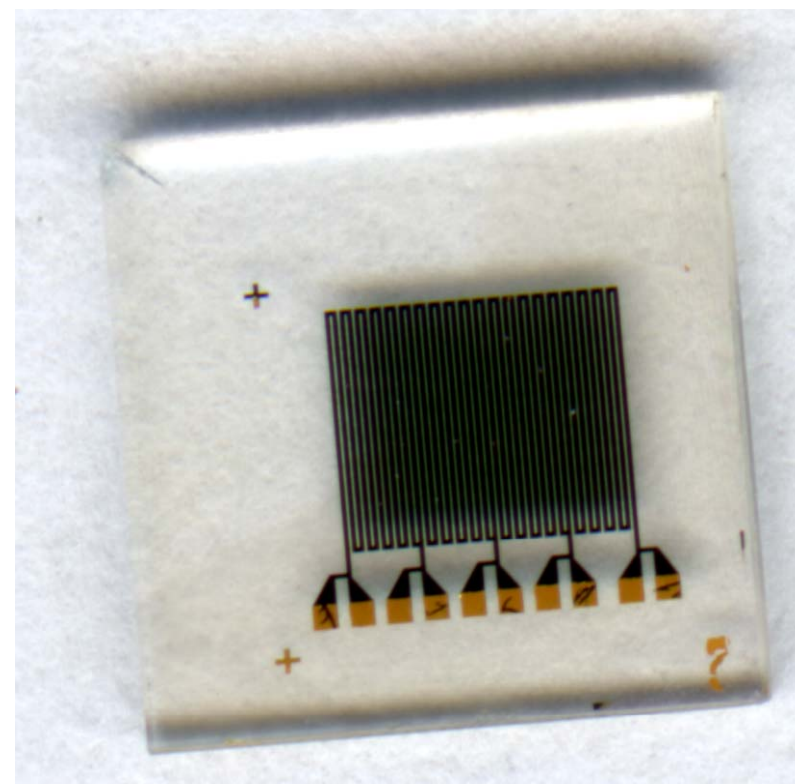



Qubduino

(Alex Hocking, Qubduino lead)

Alonzo Vera and others

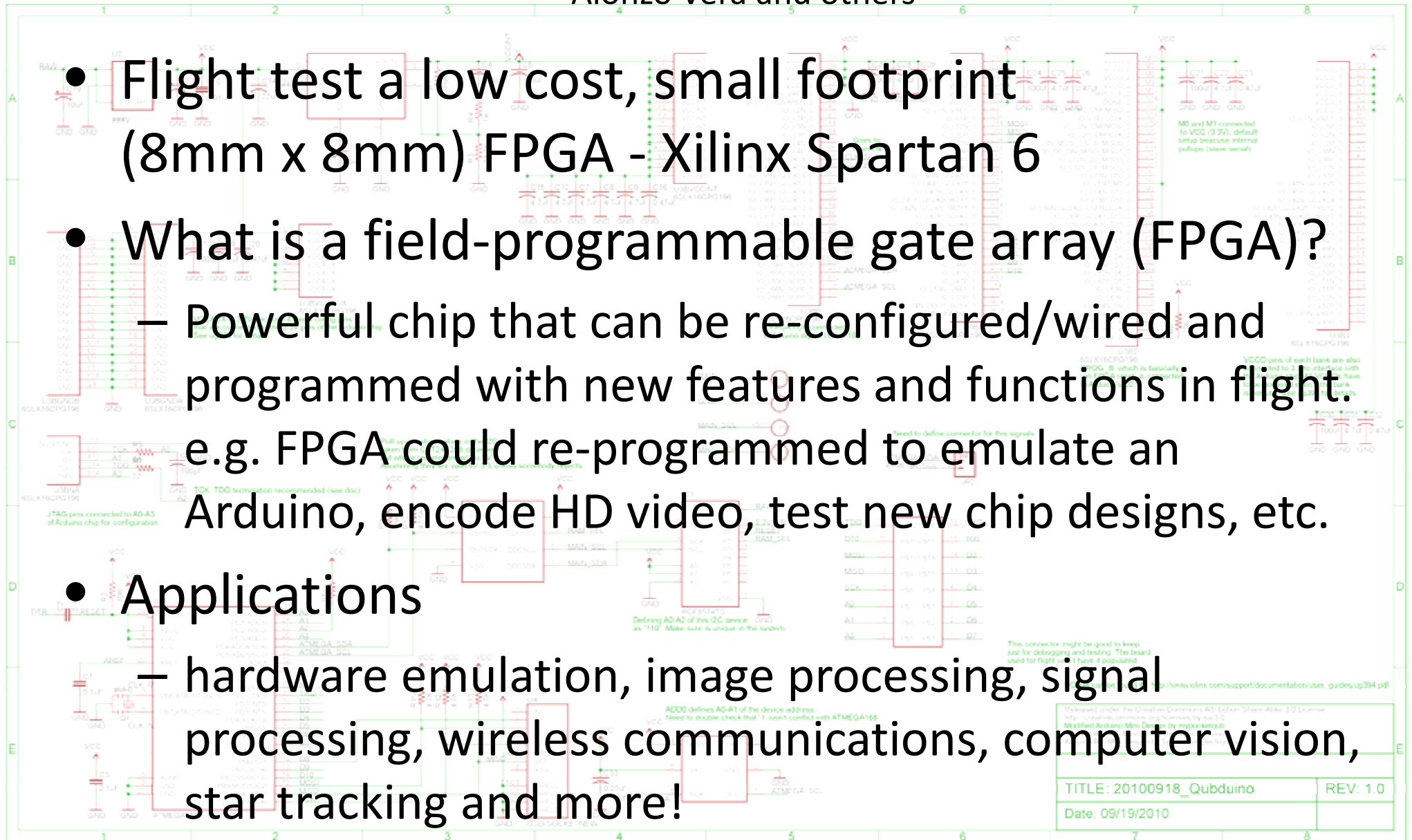
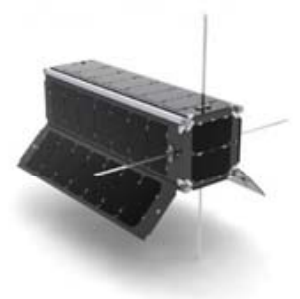



Ground control software

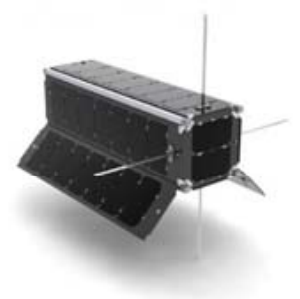

Toivo Hartikainen, Ground control software lead

Antoine Verheghe, Anum Ali, Merlin Barschke, Senol Ozkan and others

- Monitors / controls UKSEDS payloads
- For UKSEDS members, schools, public
- LabView based
 - data from web or radio
 - Easy to use
 - Real control centre theme
 - Time slider
 - Orbit track
- Useful – Educational – Fun – Open Source - Free!





OpenSpace365

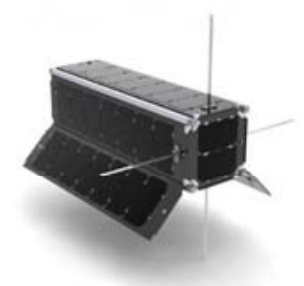

Nancy Hine, OpenSpace365 lead

Radim Badsı, Alex Hocking, Muthu Krishna, Alonzo Vera and others

- Up to 365 people can develop and fly virtual payloads for Arduino with sensors to run on-orbit for a day each for free!
- Website
 - everything you need to know to take part including submission, flight date, results, missions
 - learning zone - lesson plans, scout/guide badges, etc.
 - plus updates, blog, outreach, media, etc.
- More volunteers needed
- You don't have to be technical!



Project management

Nancy Hine, Payload co-ordinator

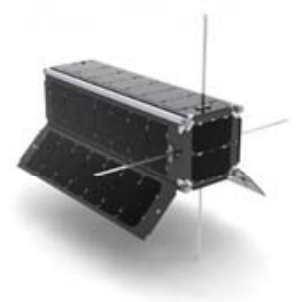

- >35 volunteers spread around the UK
- Undergraduate, M.Sc. and Ph.D students plus a few graduates
- Distributed teams, can dip in and out
- Hard deadlines from UKSA, next 9th March
- Communication is key - email, Skype, Google docs, SVN, web, etc.

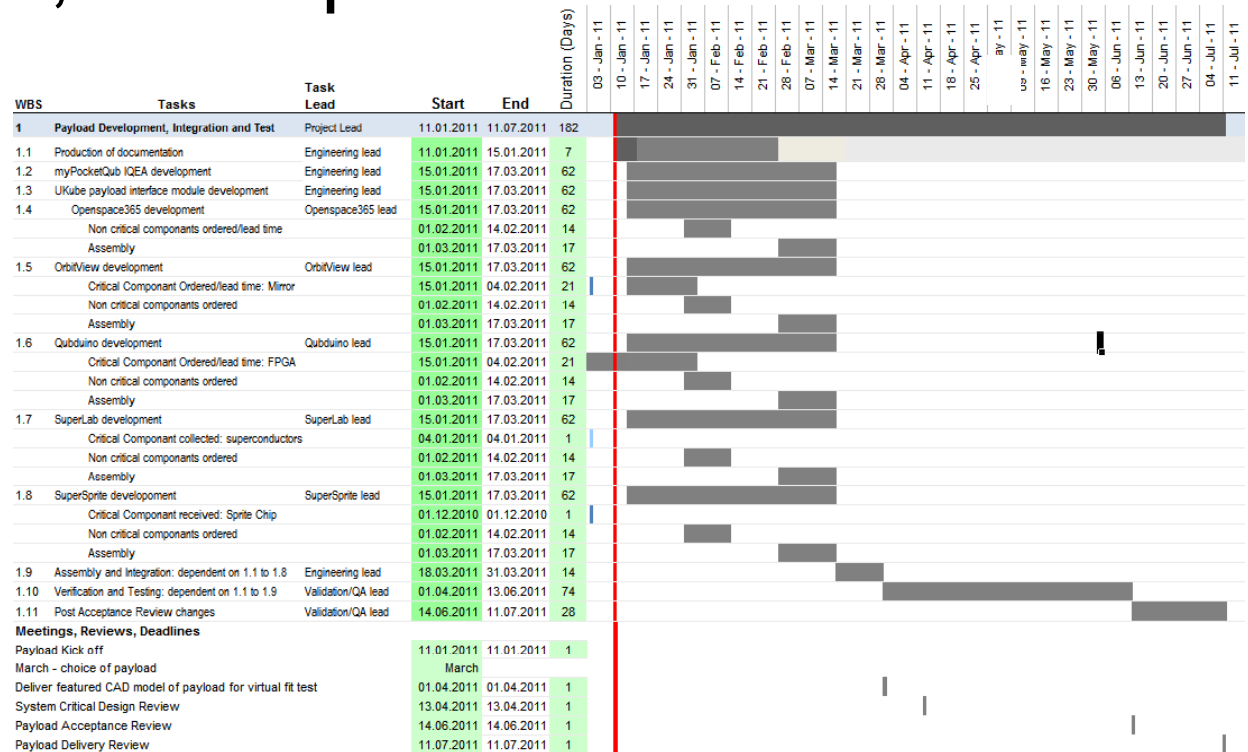



MYPOCKETQUB IQEA 442

an open source spacecraft payload

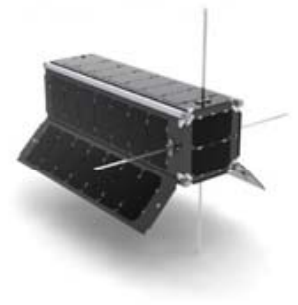

It's your project – take part!

email spaceprojects@ukseds.org

web ukseds.org/projects/ukube

